

Breakdown Sheet

The Big Bully – Pistol Grip

Model 250101 Needle Scaler Round Nose Instructions & Parts

Part Number	Description
50100	Pistol Grip Handle
50200	Barrel
50300	Piston
50400	Collar
51100	Spring
51200	Retainer Ring
52500	Locking Washer
90500	Trigger Assembly
91300	Large Rubber Seal
91301	Small Rubber Seal
91500	1/4" Steel Ball

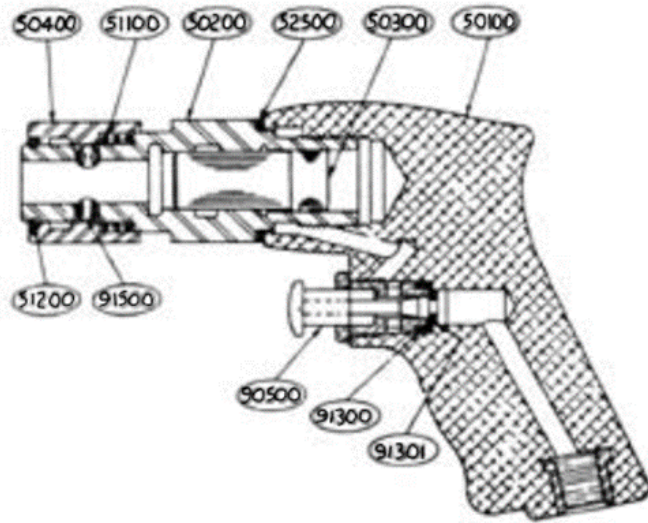

Lubrication

Before using a new tool, pour a small amount of oil into the air inlet, connect the hose, and run the tool momentarily to distribute the oil into all of the working parts. The best oil to use is Superior Pneumatic Oil, but if Superior Pneumatic Oil is not available, do not use oil heavier than SAE #10. Thereafter, insert several drops of oil into the air inlet after every two or three hours of operation. If the unit is in constant use, it must be equipped with an airline lubricator and filter.

Operation

Always wear safety goggles and protective clothing when in operation. The force and speed of the hammer blows can be regulated by the depression of the trigger. Light pressure on the trigger will start the hammer blowing at a slow rate. Full power is reached when the trigger is fully depressed. Maximum efficiency is reached when operated on 90 PSI at 6 CFM.

Caution

1. Never operate air hammers without a chisel or a chisel that is not securely against work.
2. The barrel must be kept tight at all times. A loose barrel will cause the stripping of threads in the handle and loss of power.
3. Use a hose whip directly into the inlet bushing to eliminate operator fatigue and facilitate the maneuverability of the tool.

Disassembly

1. Place the chisel in the chuck of a wrench and secure the chisel in the vise.
2. Remove the handle from the air hammer by turning it counterclockwise with the wrench.

Caution: Upon air hammer reassembly, use a new locking washer (#92500).

3. Remove the piston from the barrel.
4. Remove the retainer ring (#91200) to remove the collar (#93400).
5. Unscrew the trigger counterclockwise.

Note: Any tools needing major work should be taken to a factory or authorized repair station.

Ordering Parts

When ordering parts, the part number, serial number, and model number must be designated.

Round Nose Attachment & Instructions

Item	Part Number	Description
1	250002	Housing
2	250004	Spring
3	250024	Needles (16 req.)
4	250008	Cushion (2 req.)
5	250003	Needle Holder
6	250010	Driver
7	250007	Retainer
8	250016	Housing Strap
9	250012	Strap Nut
10	250013	Strap Screw
11	250006	Barrel Spring

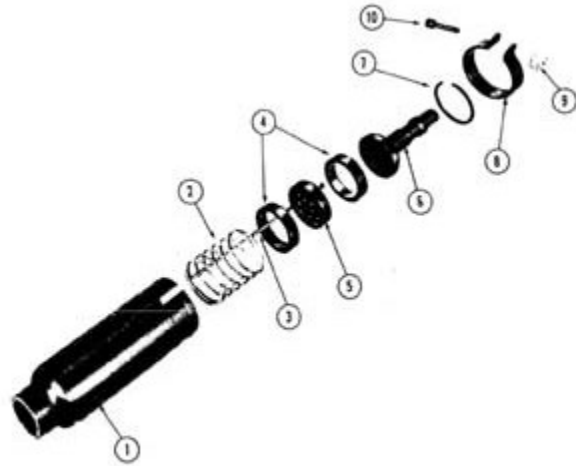

Disassembly

1. Remove the retainer (No. 250007) by prying it out with a screwdriver.
 - a. The retainer can be pried back in with a screwdriver when re-assembling.
2. Once the retainer is removed, all other parts will drop out.

Model 250200 Needle Scaler Vacuum Adapter Instructions & Parts

(For Models 240008, 250101, 250102, 250201, & 250202)

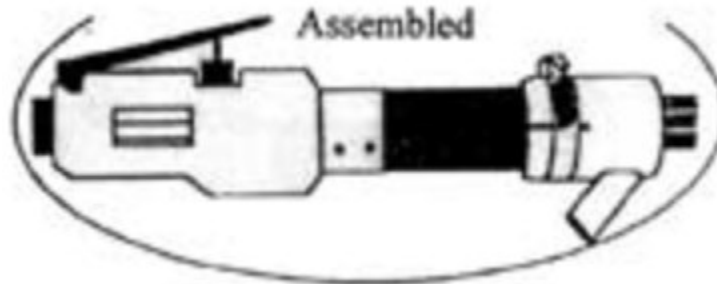
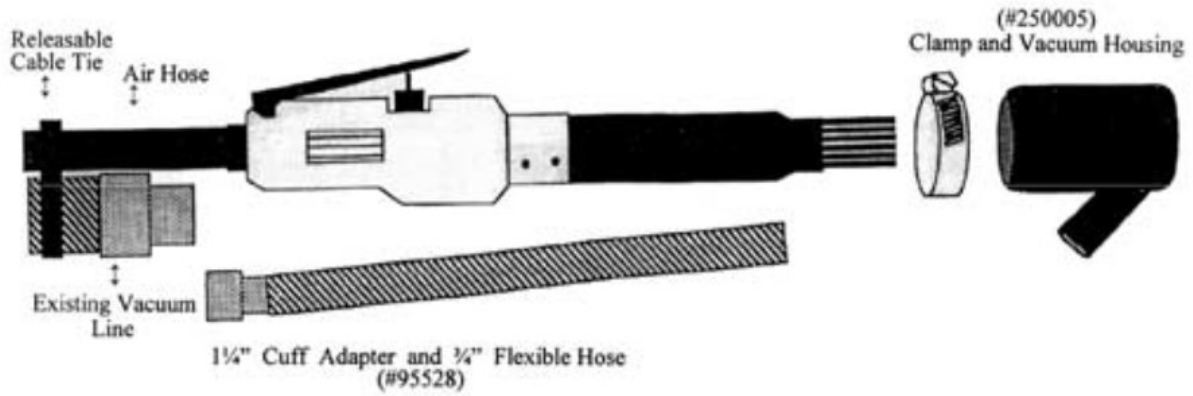

Parts Provided

Part Number	Description
250005	Clamp Vacuum Housing
95528	3/4" Flexible Hose 1 1/4" Cuff Adapter Releasable Cable Tie

Instructions

1. Slide the hose clamp over the upper end of the vacuum housing.
2. Slide the vacuum housing onto the needle scaler.
3. Adjust the hose clamp so there is a slight amount of friction between the vacuum housing and the barrel of the needle scaler.

Note: This allows some restricted up-and-down movement of the vacuum housing on the barrel of the needle scaler during use. Upward movement allows full access into corner areas and downward movement allows debris pickup when working on flat areas.

4. Attach the $\frac{3}{4}$ " flexible hose to the small exhaust port on the side of the vacuum housing.
5. Connect your existing $1\frac{1}{4}$ " vacuum line to the end of the $1\frac{1}{4}$ " cuff adapter.
6. Use the releasable cable tie to bundle the $1\frac{1}{4}$ " cuff adapter to the existing vacuum line near the handle of the needle scaler.

Note: This keeps the vacuum hose out of the operator's way and prevents the hose from being dislodged during use.